

C4 1964 Valve Body
 Use "SK 4" Shift Kit®
 No HD kit for 64 VB

C4 Casting Number
On Valve Body/

LISTEN UP: Install all the end plate bolts loosely. **LAST THING:** Tighten plate bolts.

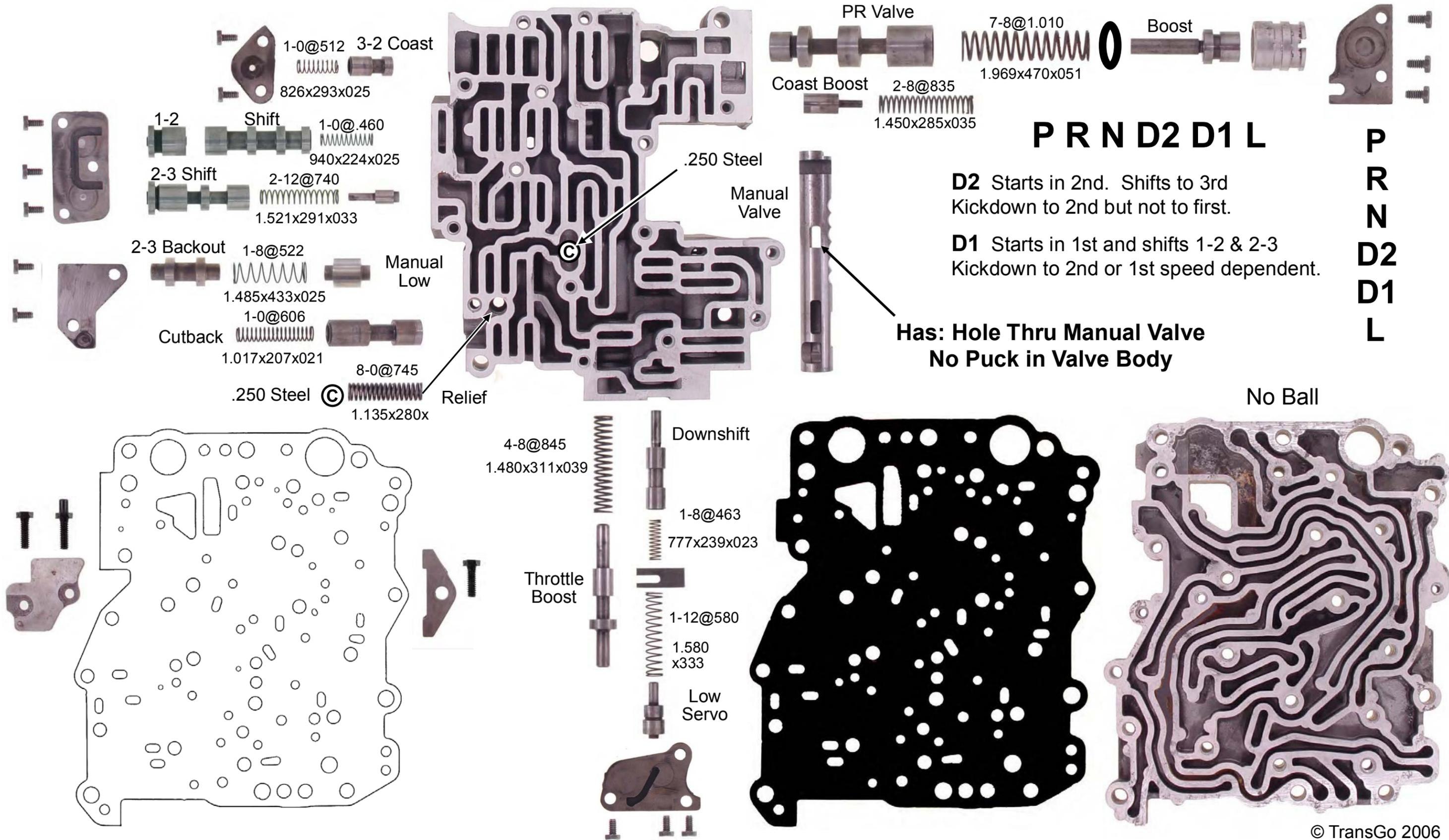

P R N D2 D1 L

D2 Starts in 2nd. Shifts to 3rd
 Kickdown to 2nd but not to first.

D1 Starts in 1st and shifts 1-2 & 2-3
 Kickdown to 2nd or 1st speed dependent.

P
R
N
D2
D1
L

Has: Hole Thru Manual Valve
No Puck in Valve Body

No Ball

C4 64-66 Valve Body
 Use "SK 4L" Shift Kit®
 Use "45-1" HD Kit

C5 Casting Number
 On Valve Body/

LISTEN UP: Install all the end plate bolts loosely. **LAST THING:** Tighten plate bolts.

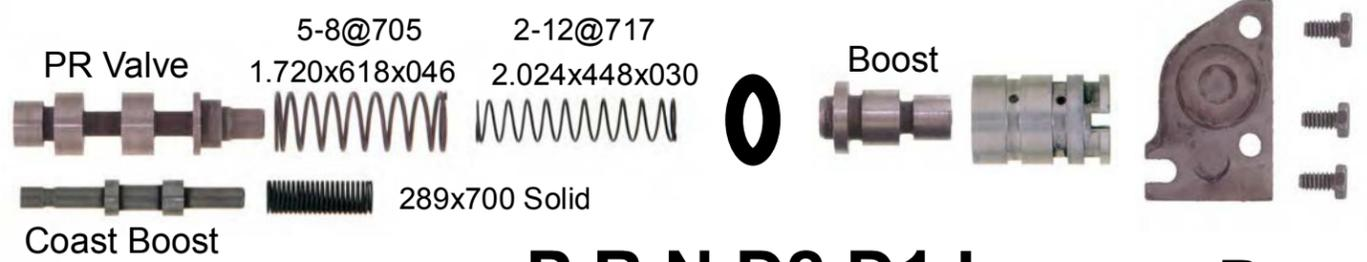
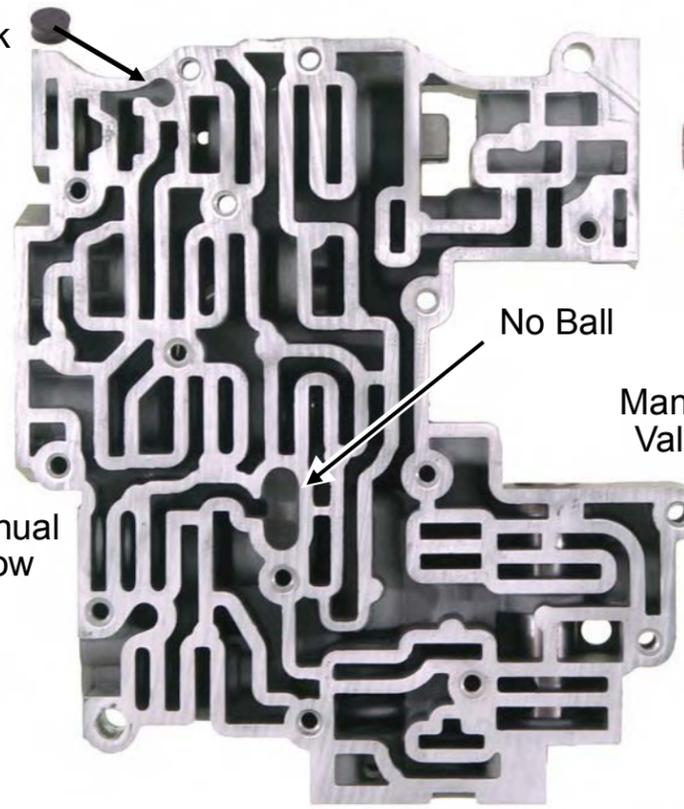
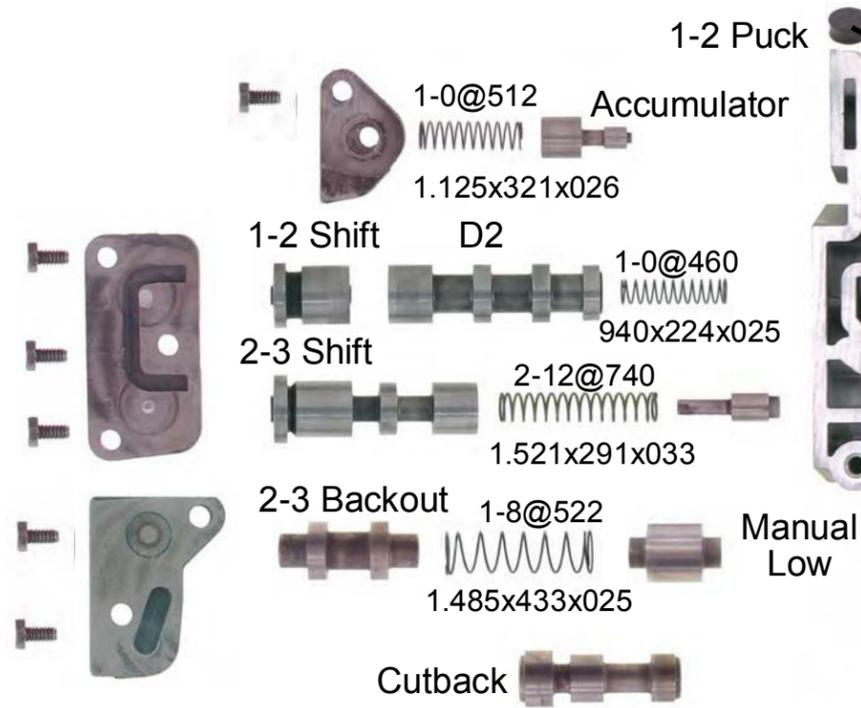

P R N D2 D1 L

D2 Starts in 2nd. Shifts to 3rd
 Kickdown to 2nd but not to first.
D1 Starts in 1st and shifts 1-2 & 2-3
 Kickdown to 2nd or 1st speed dependent.
L Starts off and stays in Low [1st]

**P
 R
 N
 D2
 D1
 L**

**Has: Hole Thru Manual Valve
 No Check Balls in Valve Body**

No Ball

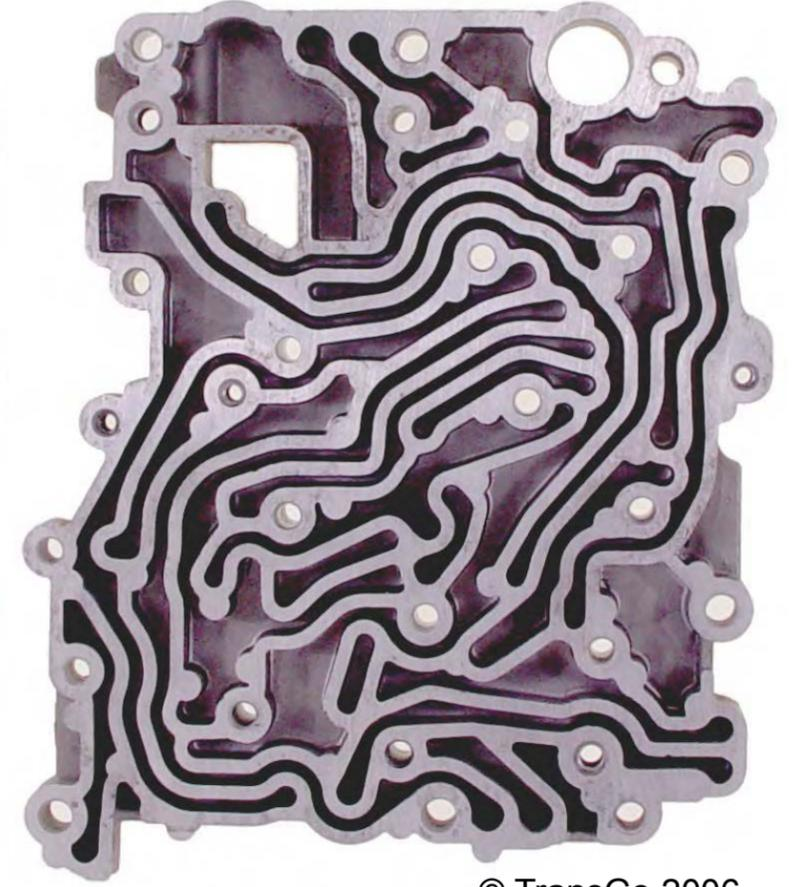
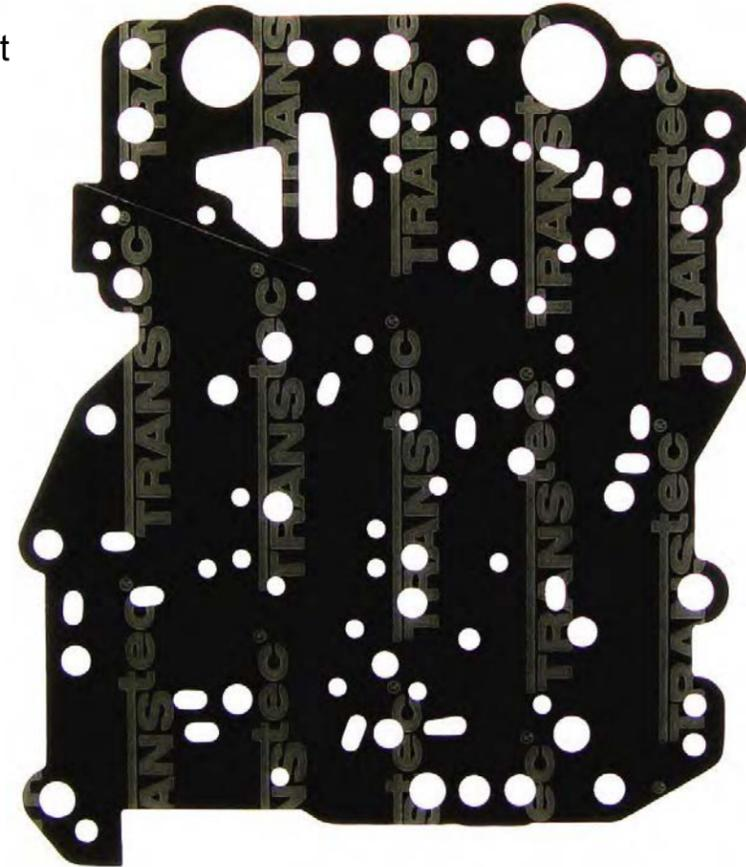
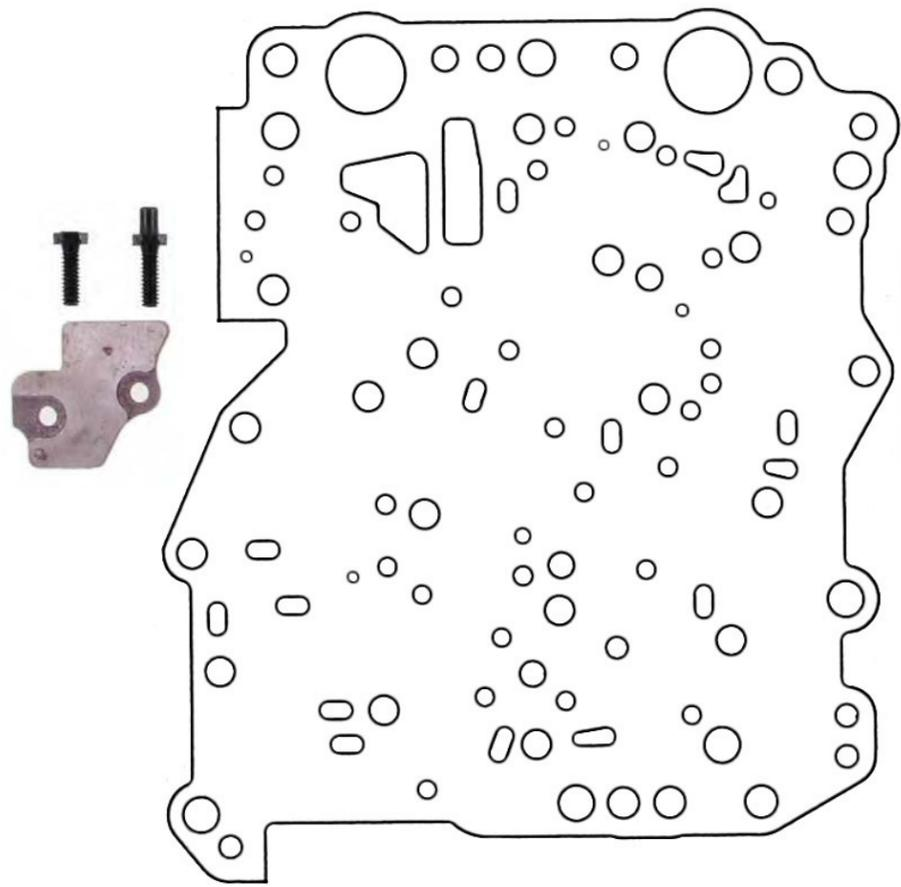

J AI CELUI CI SUR MA C4 , c'est un C8 avec le kit Transgo 47-2

C4 67- 69 Valve Body
 Use "SK 4S" Shift Kit®
 Use "47-1", "47-2" or "47-3" HD kit

C7 Casting Number
On Valve Body/Channel

LISTEN UP: Install all the end plate bolts loosely. **LAST THING:** Tighten plate bolts.

1-2 Puck
 Accumulator 1-8@428 1.300x436x028
 1-2 Shift D2 1-0@460 940x224x025
 2-3 Shift 2-12@.740 1.521x291x033
 2-3 Backout 1-8@.522 1.485x433x025
 Manual Low
 Cutback
 PR Valve 6-8@797 2.420x618x047
 Coast Boost 3-4@452 1.060x343x030
 Boost 1-8@717 1.657x410x030
 .217 Plastic Ball
 Manual Valve
PRND21
D Starts in 1st and shifts 1-2 & 2-3
 Kickdown to 2nd or 1st, speed dependent.
2 Starts off and stays in 2nd.
1 Starts off and stays in low [1st]
No Hole Thru Manual Valve
**P
R
N
D
2
1**

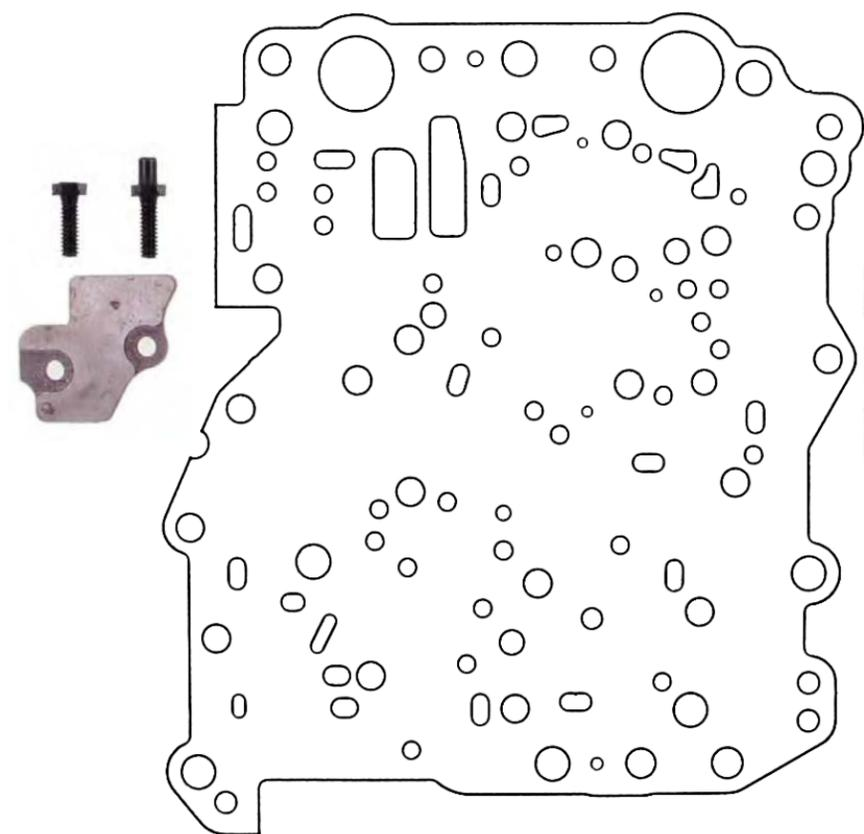

Downshift
 5-0@767 1.420x325x034
 Throttle Boost
 1.035x356x030 3-0@466

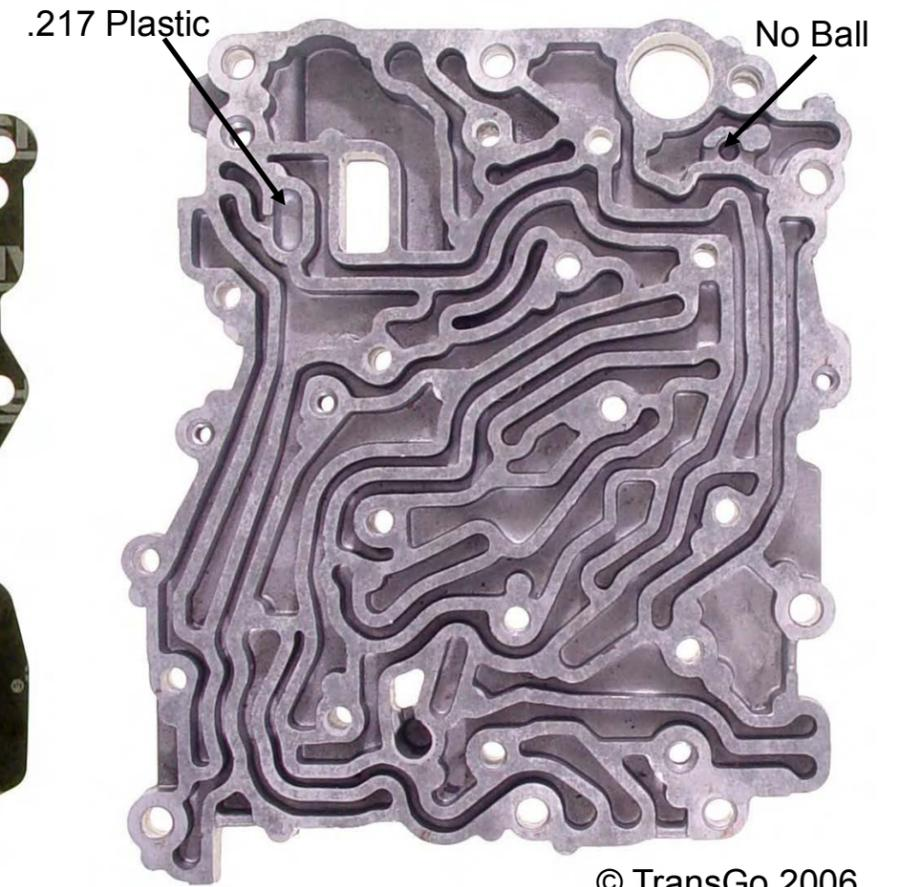
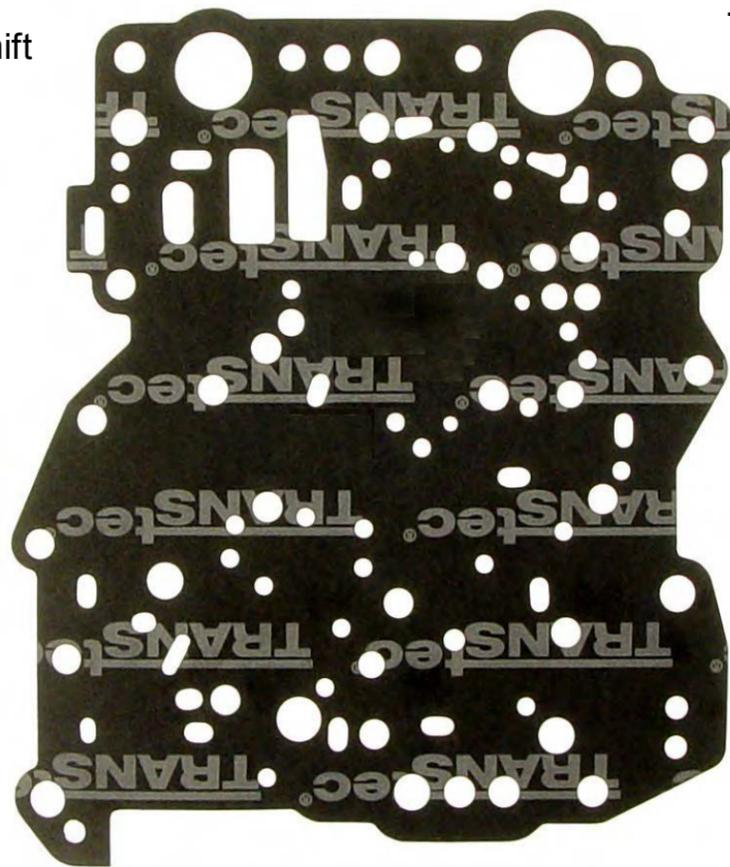

C4 70!Up Valve Body
 Screw in Modulator
 Use "SK 4-71" Shift Kit®
 Use "40-2" or "40-3" HD Kit
 Push in Modulator 71-Up
 Use "SK C5" No HD Kit

D0 to D7 Casting Number
 On Valve Body/Channel

LISTEN UP: Install all the end plate bolts loosely. **LAST THING:** Tighten plate bolts.

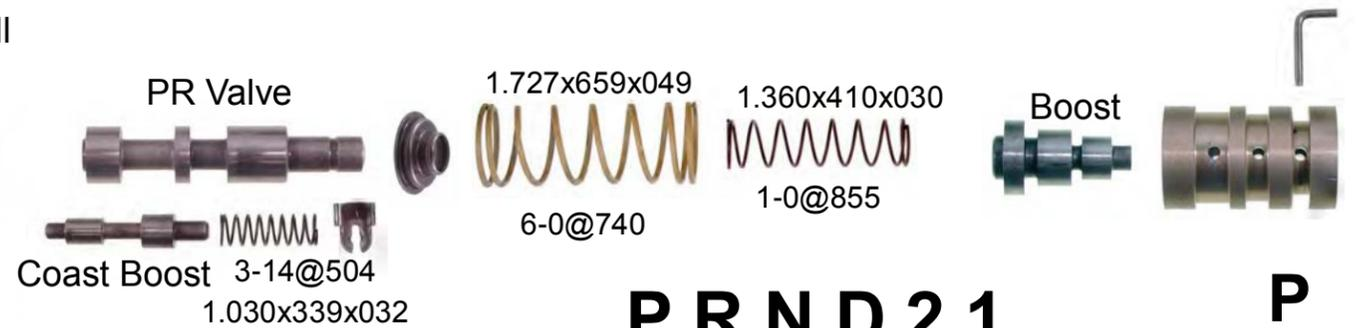
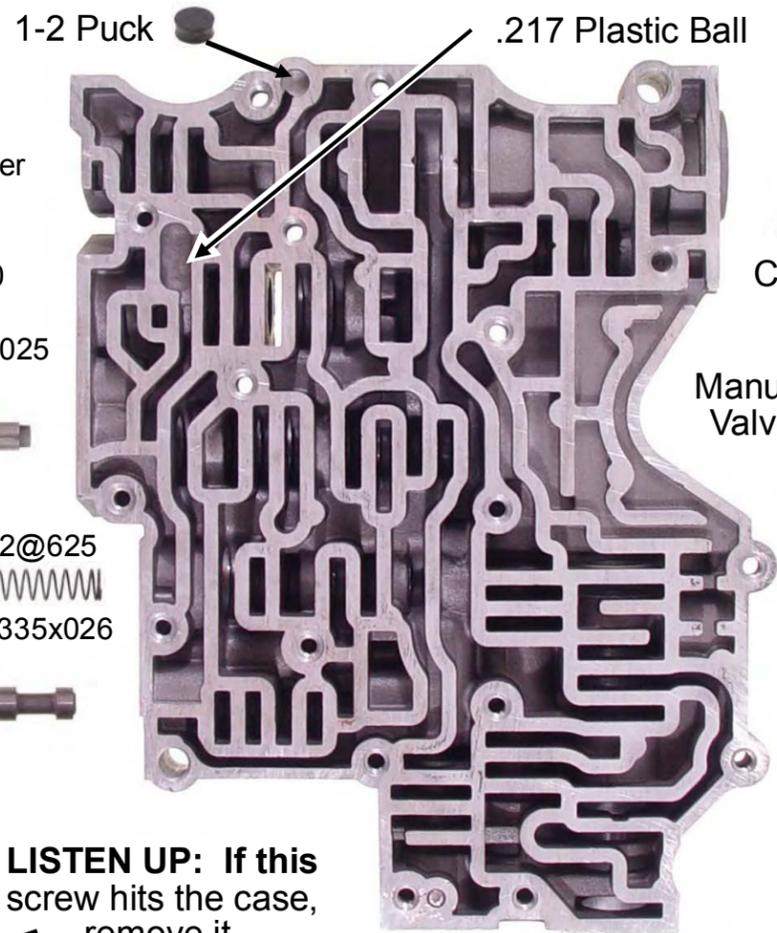

PRND21

- D** Starts in 1st and shifts 1-2 & 2-3. Kickdown to 2nd or 1st, speed dependent.
- 2** Starts off and stays in 2nd.
- 1** Starts off and stays in Low [1st]

**P
R
N
D
2
1**

Manual Valve



Spindle Type Manual Valve

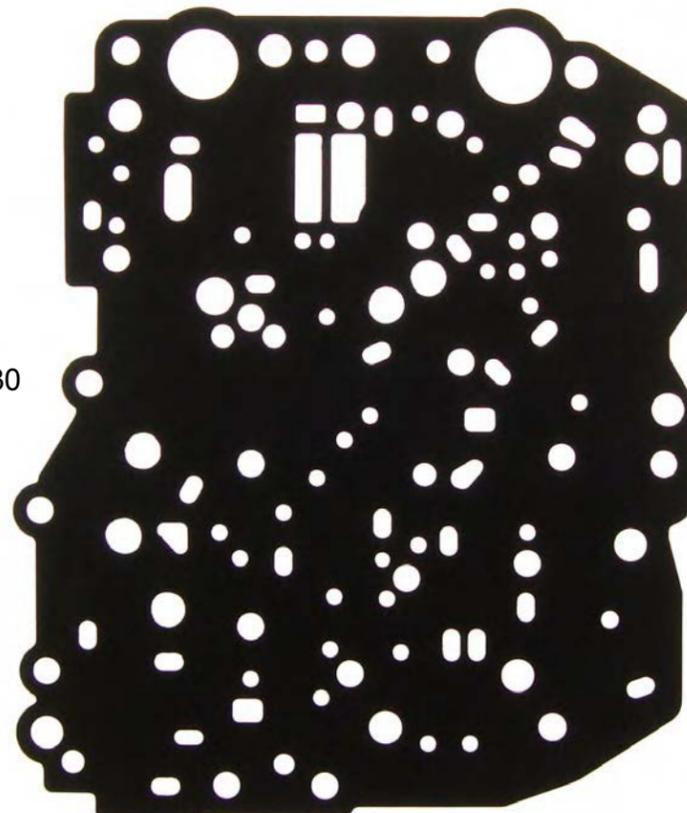
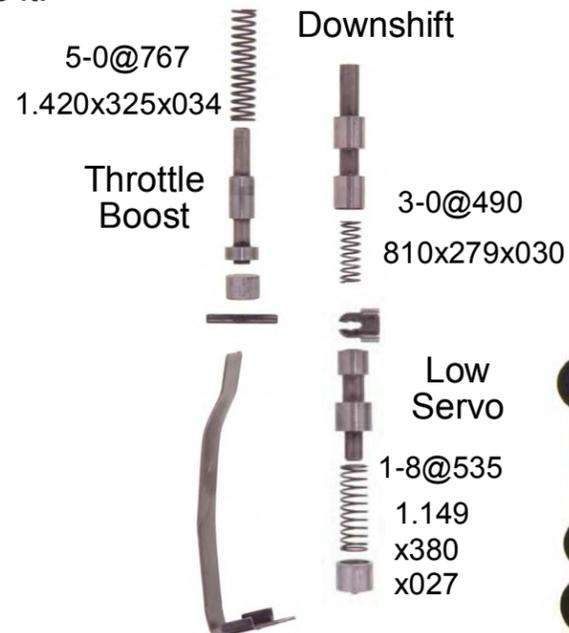
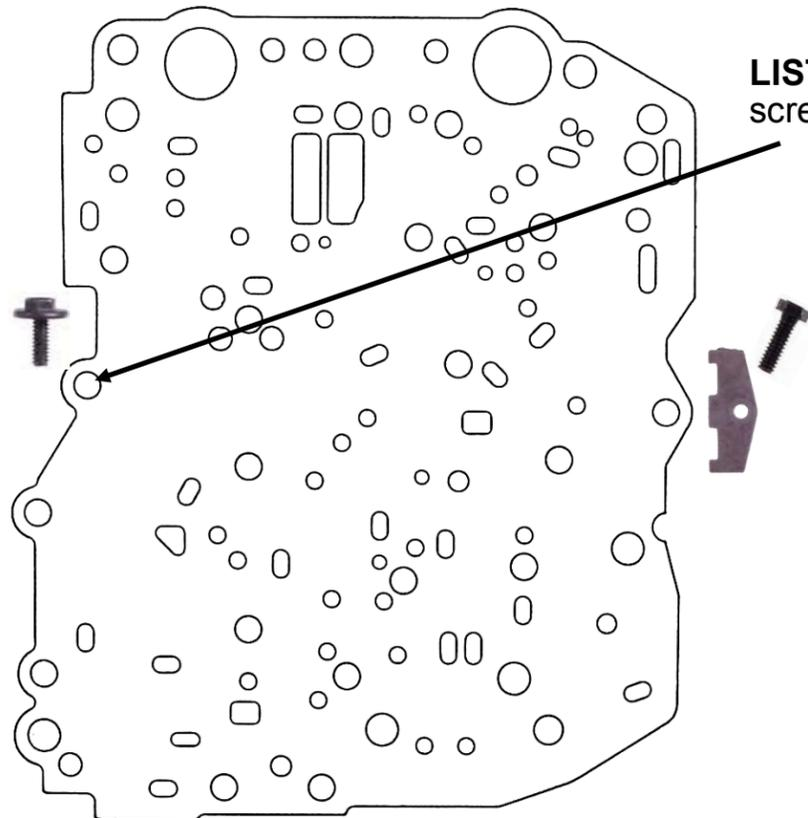

C5 Valve Body Use "SK C5" Shift Kit® No HD Kit for C5

D8 to E2 Casting Number On Valve Body/Channel

• **LISTEN UP:** Install all the end plate bolts loosely. **LAST THING:** Tighten plate bolts.

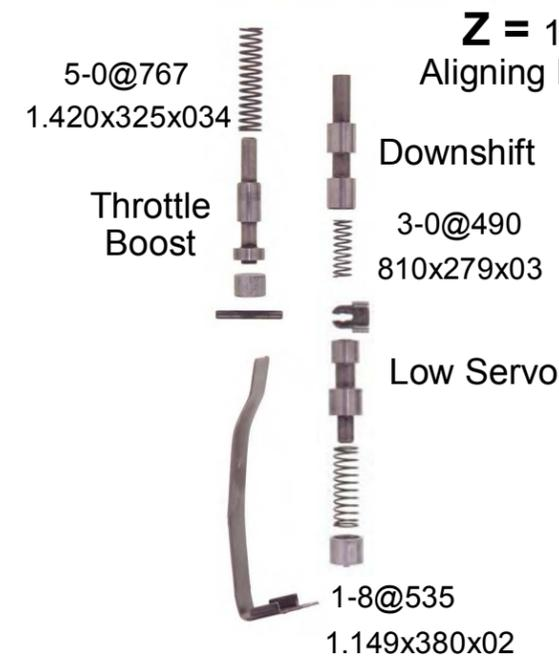
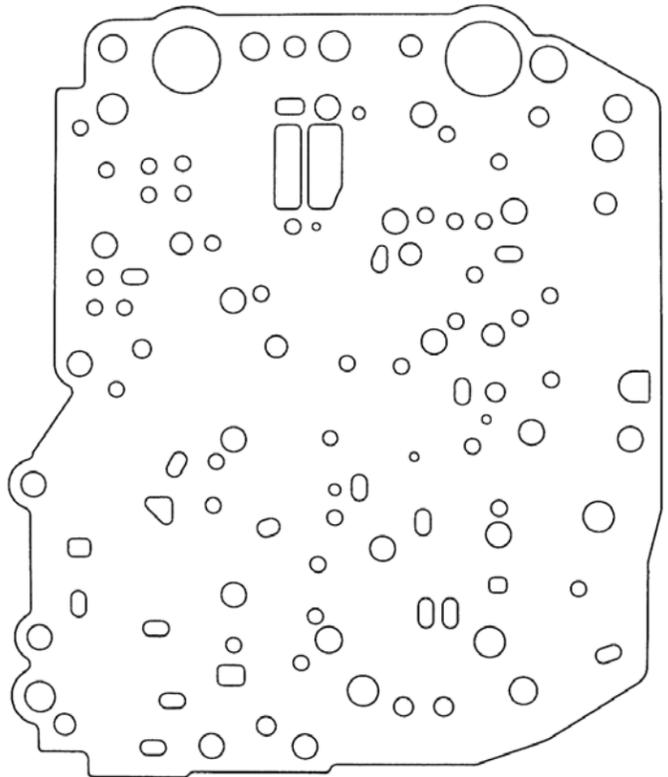
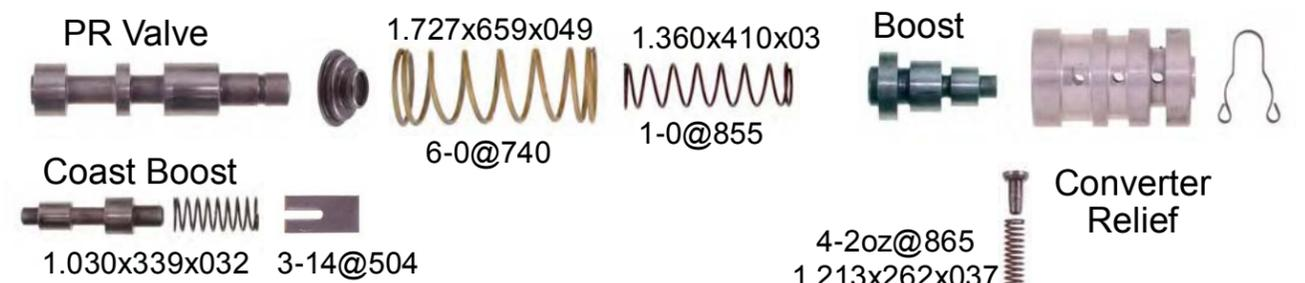
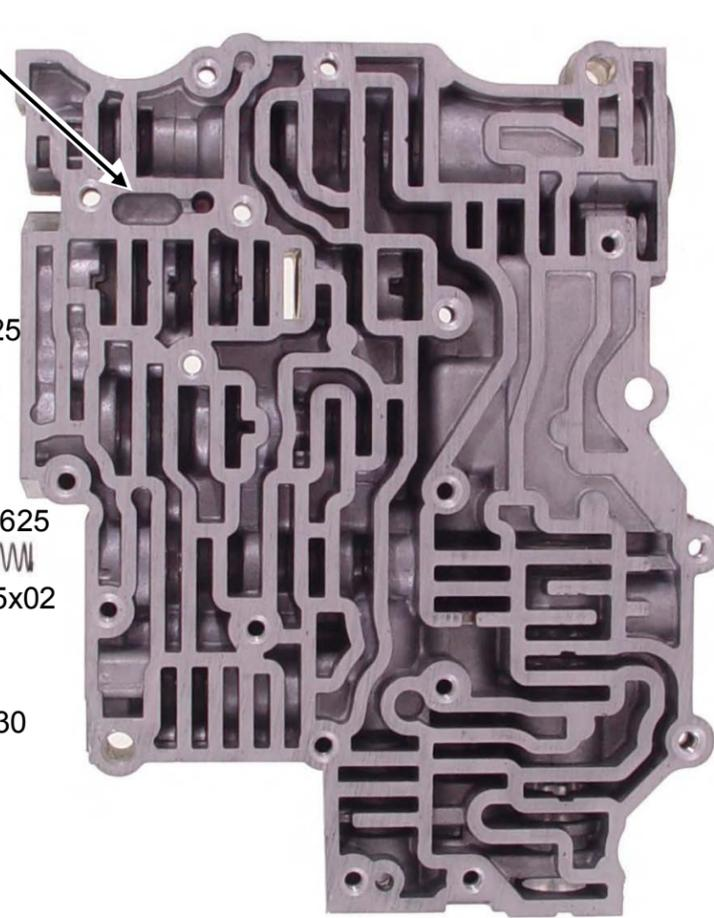
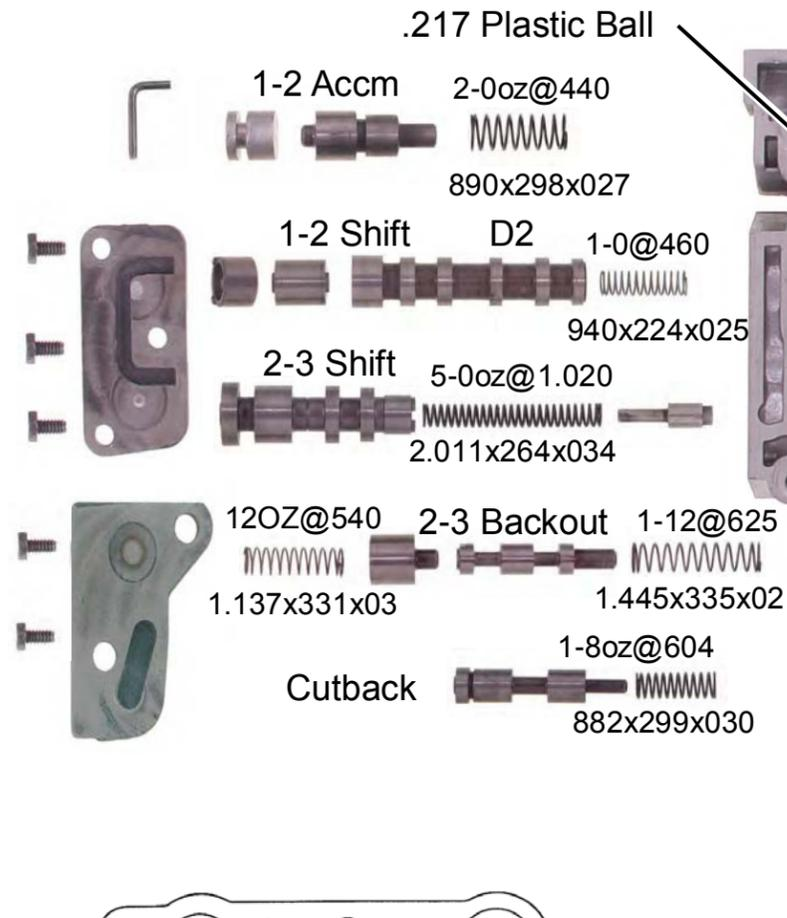

Z = 1/4" Aligning Holes

